



ASHOK LEYLAND

SUPER STALLION 10x10

DIMENSIONS (mm)

Wheel Base	5850 / 6500
Overall Length	9850 to 10750
Overall Height	3000 / 3230
Overall Width	2500
Loading Span	6600 to 7700
Ground Clearance	400
Angle of Approach/Departure	35° / 25°, 30°, 35°

WEIGHTS (kg)

Unladen	13000
Laden	32000
Payload	19000

PERFORMANCE

Max. Powered Speed	90 kmph
Max. Gradeability	30°
Min. Turning Circle Diameter	25 m, 29 m

OPTIONS

Drive	LHD / RHD
Transmission	Manual / Automatic

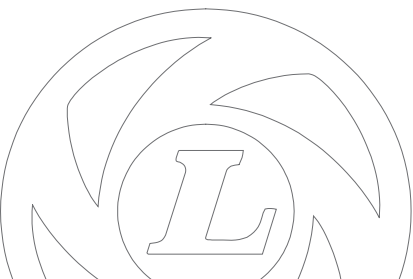

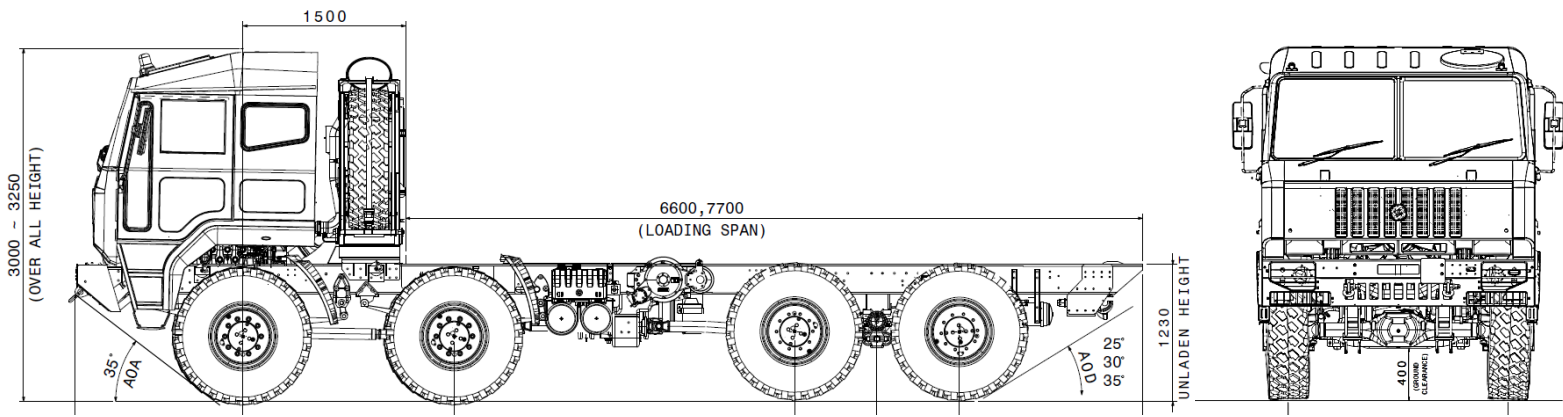

ENGINE

Power	265 kW (360 hp)/ 330 kW (450 hp at 2200 rpm)
Torque	1400 Nm at 1300-1500 rpm/ 1627 Nm at 1300 rpm
Fuel Tank Capacity	350 Litres

CLUTCH

Type	Diaphragm pull type
------	---------------------

GEAR BOX

Type	Manual 9 speed / Automatic
------	----------------------------

TRANSFER CASE

Type	Twin speed
------	------------

AXLES

Type	Hub reduction axles with provision for inter-axle lock and inter wheel differential lock & CTIS.
------	--

SUSPENSION

Type	Front: Parabolic Rear: Bogie
------	---------------------------------

STEERING

Type	Integral power Steering
------	-------------------------

BRAKES

Type	Dual Line – Full air brakes
------	-----------------------------

ELECTRICAL SYSTEM

System voltage	24V
Batteries	150AH / 200 AH

WHEELS & TYRES

Tyre Size	14.00 x 20
Rim Size	10.00 x 20

CAB

Type	Sleeper Cab
Optional	<ul style="list-style-type: none"> • Air Conditioning • Up-Armouring • Winch upto 12 T capacity • Material Handling Crane • NBC • Emergency Power Steering

Note: Ashok Leyland Ltd. has a policy of continual product improvement. The specifications shown here are indicative and are subject to change without prior notice.